

**EN**

Original Instructions  
Version 1

**DRAPER**<sup>®</sup>

**D20**

**MULTI-TOOL BATTERY SYSTEM**

20V

# **AIR COMPRESSOR**

**08093**



**UK  
CA** **CE**

# 1. Preface

These are the original product instructions. This document is part of the product; retain it for the life of the product, passing it on to subsequent holders. Read this manual in full before attempting to assemble, operate or maintain this product.

This Draper Tools manual describes the purpose of the product and contains all the necessary information to ensure its correct and safe use. Following all the instructions and guidance in this manual will ensure the safety of both the product and the operator and increase the lifespan of the product.

All photographs and drawings within this manual are supplied by Draper Tools to help illustrate correct operation of the product.

Every effort has been made to ensure the information contained in this manual is accurate. However, Draper Tools reserves the right to amend this document without prior warning. Always use the latest version of the product manual.

## 1.1 Product Reference

**User Manual for:** D20 20V Cordless Air Compressor, 4L (Bare)

**Stock No:** 08093

**Part No:** D20AC4L

## 1.2 Revisions

**Version 1:** February 2023  
First release

For the latest version of this manual and the associated parts list, if applicable, please visit [drapertools.com/manuals](http://drapertools.com/manuals)

## 1.3 Understanding the Safety Content of This Manual



**WARNING!** – Situations or actions that may result in personal injury or death.



**CAUTION!** – Situations or actions that may result in damage to the product or surroundings.

**Important:** – Information or instructions of particular importance.

## 1.4 Copyright © Notice

Copyright © Draper Tools Limited.

Permission is granted to reproduce this manual for personal and educational use **ONLY**. Commercial copying, redistribution, hiring or lending is strictly prohibited.

No part of this manual may be stored in a retrieval system or transmitted in any other form or means without written permission from Draper Tools Limited.

In all cases, this copyright notice must remain intact.

1.	Preface	2
1.1	Product Reference	2
1.2	Revisions	2
1.3	Understanding the Safety Content of This Manual	2
1.4	Copyright © Notice	2
2.	Contents	3
3.	Warranty	4
4.	Product Introduction	5
4.1	Scope	5
4.2	Specification	5
5.	Health and Safety Information	7
5.1	General Health and Safety Precautions	7
5.2	Additional Safety Instructions for This Air Compressor	7
5.3	Additional Safety Instructions for Rechargeable Batteries	8
5.4	Residual Risk	8
6.	Identification and Unpacking	9
6.1	Product Overview	9
6.2	Packaging	9
7.	Operating Instructions	10
7.1	Inserting and Removing the Battery Pack	10
7.2	Connecting an Air Line or Tool	11
7.3	Pressurising the Compressor Tank	12
7.4	Setting the Output Pressure	12
7.5	Depressurising the Compressor Tank	13
7.6	The Safety Valve	13
7.7	Thermal Overload Protection	13
7.8	Moisture in Compressed Air	13
8.	Maintenance and Troubleshooting	14
8.1	General Maintenance	14
8.2	Draining Moisture from the Compressor Tank	14
8.3	Storing the Compressor	15
8.4	Troubleshooting	15
9.	Spares, Returns and Disposal	17
10.	Explanation of Symbols	18

### 3. Warranty

---

Draper Tools products are carefully tested and inspected before shipment and are guaranteed to be free from defective materials and workmanship.

Should the tool develop a fault, return the complete tool to your nearest distributor or contact Draper Tools directly. Contact information can be found at the back of this manual.

Proof of purchase must be provided.

If, upon inspection, it is found that the fault occurring is due to defective materials or workmanship, repairs will be carried out free of charge. This warranty period covers parts and labour for 12 months from the date of purchase. Where tools have been hired out, the warranty period covers 90 days from the date of purchase.

This warranty does not apply to any consumable parts, batteries or normal wear and tear, nor does it cover any damage caused by misuse, careless or unsafe handling, alterations, accidents, or repairs attempted or made by any personnel other than the authorised Draper Tools repair agent.

In all cases, to make a claim for faulty workmanship or materials within the standard warranty period, please contact or return the product to the place of purchase. Proof of purchase may be required.

If the place of purchase is no longer trading or if you experience any difficulties with your warranty, please contact Customer Services with the product details and your proof of purchase. Contact details can be found at the back of this manual.

If the tool is not covered by the terms of this warranty, repairs and carriage charges will be quoted and charged accordingly.

This warranty supersedes any other guarantees expressed or implied and variations of its terms are not authorised.

Your Draper Tools guarantee is not effective until you can produce, upon request, a dated receipt or invoice to verify your purchase within the guarantee period.

Please note that this warranty is an additional benefit and does not affect your statutory rights.

#### **Draper Tools Limited**

# 4. Product Introduction

## 4.1 Scope

This product is designed to generate a supply of compressed air at up to the rated pressure for use in operations such as air-brushing and toy and tyre inflation.

**Important:** This product is suitable for pressurising air **ONLY** and must **NOT** be used to pressurise any other gas.

 **CAUTION! This product is NOT continuously rated and is for intermittent use ONLY. DO NOT use this product with the compressor continuously repressurising.**

Part of our core range, this product is suitable for regular use by enthusiasts and tradespersons alike.

 **WARNING! This product is not a toy and must be respected.**

Read this manual in full before attempting to assemble, operate or maintain the product, and retain it for later use.

## 4.2 Specification

Stock No.:	08093
Part No.:	D20AC4L
Rated voltage:	20V
Duty cycle:	90 seconds in 10 minutes
Motor:	
Speed:	4,200rpm
Cut-out pressure:	8bar
Cut-in pressure:	5.4bar
Max. pressure:	8bar (116psi)
Safety valve:	8.3~9.13bar
Tank size:	3.785L
Air outlet:	Female Euro adaptor with 1/4" BSP thread
Air flow:	
90psi:	0.6m <sup>3</sup> /h
40psi:	1.3m <sup>3</sup> /h
Pressurising speed:	90s approx. (0–8bar)
Running time:	14.5min (1 x 4.0Ah battery)
Noise emissions:	
Sound pressure level:	66.6dB(A)
Uncertainty:	2.3dB(A)
Sound power level:	89dB(A)
Uncertainty:	2.3dB(A)
IP rating:	IP20
Dimensions:	W 305 H 410 x D 400mm
Net weight:	7.7kg

## 4. Product Introduction

---

### Battery packs (sold separately):

Stock No.	55907	55898
Part No.	D20B5.0AH	D20B4.0AH
Type	Li-ion	Li-ion
Rated voltage	20V	20V
Rating	5.0Ah	4.0Ah

### Chargers (sold separately):

Stock No.	97914	55913
Part No.	D20BCS/2	D20BCF
Rated voltage	230V~	230V~
Rated frequency	50Hz	50Hz
Rated output	35W	35W
Rated DC output voltage	20V	20V
Rated DC output current	2.4A	2.0A
Construction	Class II	Class II

**Important:** The declared noise emissions values have been measured in accordance with a standard test method and may be used for comparing one tool with another. These values may also be used in a preliminary assessment of exposure.



**WARNING!** The noise emissions during actual use of the product can differ from the declared values depending on the output pressure and the tools with which it is used. Before each use, estimate the likely exposure resulting from the actual conditions of use. Take into account all parts of the operation cycle in order to identify any safety measures required to protect the operator.

## 5.1 General Health and Safety Precautions

- Only authorised personnel who have carefully read and understood this manual may operate, adjust and maintain this product.
- Observe all standard safety precautions and good practices when working with air tools and compressed air.
- Always wear adequate eye and ear protection when using this product.
- Wear protective gloves while using this product.
- Keep your work environment clear and well-lit, with bystanders at a safe distance.
- Use this product **ONLY** in well-ventilated environments where no air pollutants, dust, acids, or flammable, explosive or toxic vapours are present.
- Before every use, inspect the product for missing, broken, loose or corroded parts and leaks.  
**Important: DO NOT** use this product if it is damaged or leaking in any way. Contact Draper Tools to discuss repair and replacement options.
- **DO NOT** use this machine if the on/off switch does not function correctly.
- **DO NOT** use this product if either of the gauges are unresponsive or inaccurate.
- Ensure that all connections are securely fastened before use.
- Use the product only in the manner instructed in this manual.
- **DO NOT** modify this product in any way.
- **DO NOT** adjust the safety valve.
- **ALWAYS** ensure that the motor air vents are clear and free from dust and debris during use.
- **DO NOT** cover any part of this product during operation.
- **NEVER** immerse this product in water or expose it to damp conditions or frost.
- **ALWAYS** use, store and transport this product in an upright position.
- **ONLY** use spare parts supplied by Draper Tools.
- Stay alert at all times; **DO NOT** use this product while tired or under the influence of alcohol, drugs or other medication.

- Position the product in an upright position on a firm and flat surface during use and ensure that it is not likely to fall.
- **DO NOT** move the compressor while it is switched on.
- **NEVER** leave this product unattended while it is pressurising, pressurised or in use.

## 5.2 Additional Safety Instructions for This Air Compressor

**Important: ALWAYS** check local regulations regarding pressure vessels before use.



**WARNING! The air produced by this product is NOT suitable for breathing equipment.**

- Compressed air can cause severe injury.
  - **ALWAYS** turn off and disconnect the air supply before making any adjustments to the attached tools.
  - **NEVER** direct compressed air towards yourself or others.
  - Ensure that compressed air is not blocked by or in contact with any part of your body.
- This product is not intended for use by persons (including children) with reduced physical, sensory or mental capabilities, or lack of experience and knowledge.
  - Children should be supervised to ensure that they do not play with the product.
- Draper Tools recommends the use of a whip hose between the tool and the air supply to reduce vibration.



**CAUTION! Whipping hoses can cause severe injury. Always check for and replace damaged or loose hoses and fittings.**

- Ensure that any connected tool is compatible with the air supply before use.
- **ALWAYS** ensure that the air flow is shut off when connecting an air line or tool.
  - Pressurise the compressor tank before connecting an air line or tool and set the regulator to its minimum setting.
  - **DO NOT** depress the tool trigger or open the air line while connecting them to the compressor.

## 5. Health and Safety Information

---

- **DO NOT** exceed the maximum stated air pressure of this compressor or any connected tools.
  - The pressure of the air supply **MUST NOT** exceed more than 10% of the rated pressure of any connected tool.
- **NEVER** carry the compressor or any connected tool by the air line.
- **DO NOT** use this tool in temperatures that do not fall within 0–40°C.
- **DO NOT** use this product to supply air tools that require greater air flow than this compressor can provide.
- **NEVER** strike or pierce the compressor tank or expose it to flames sources or sources of heat.
- **DO NOT** use this product if you suspect that the integrity of the compressor tank has been compromised.
- **NEVER** weld anything to or drill holes in the compressor tank.
- Drain the compressor tank of condensation before and after **EVERY** use and before storing the product.
- Have the safety valve replaced every 12 months by an authorised service agent.

 **WARNING! DO NOT use this product if the safety valve or gauges are damaged in any way. The tank pressure must be monitorable and able to self-vent in the event of over-pressurisation.**

 **WARNING! This product may become hot during use. DO NOT touch the motor housing or compressor tank during use. Allow the product to cool before adjusting, moving or maintaining the product.**

 **WARNING! ALWAYS depressurise the tank after use; DO NOT store the compressor with a pressurised tank.**

### 5.3 Additional Safety Instructions for Rechargeable Batteries

**Important:** Use **ONLY** Draper Tools D20 range 4.0Ah (Stock No. 55898) and 5.0Ah (Stock No. 55907) battery packs and chargers with this product (not supplied). Read all instructions supplied with the batteries and charger before use.

 **WARNING! DO NOT use or charge the battery if leakage is evident.**

- Recharge batteries **ONLY** using the charger specified.
- **DO NOT** open, crush or burn the battery as this may release potentially harmful chemicals.
- **DO NOT** expose the battery to temperatures greater than 50°C.
- Charge the battery in a dry and well-ventilated environment in ambient temperatures between 5 and 40°C, ensuring that the ventilation slots on the charger casing are not obstructed.
- **DO NOT** attempt to charge batteries that exhibit a temperature that is not between 5 and 30°C.
  - Allow batteries that are too hot or too cold to normalise before charging.
- **DO NOT** short-circuit the battery by connecting the positive and negative terminals while it is outside of the product.
  - Keep the battery away from metallic objects that may inadvertently cause a connection between the terminals.
- **DO NOT** expose the battery pack to rain or other wet conditions or immerse it in liquid.
- **ALWAYS** remove the battery before storing the product for extended periods.
- **ALWAYS** remove the battery from the tool before recycling and dispose of it in accordance with local regulations.
- If a fire occurs, use a CO<sub>2</sub> or dry chemical extinguisher.

 **WARNING! The electrolyte in the battery pack is corrosive. Avoid contact with skin.**

If contact occurs, flush the area with clean water and pat it dry. Seek medical attention at the earliest opportunity and inform the responder that the contaminant is a “high-alkaline corrosive liquid”. If contact with the eyes occurs, flush immediately with plenty of water **ONLY** and seek medical advice at the earliest opportunity.

### 5.4 Residual Risk

The safety instructions in this manual cannot account for all possible conditions and situations that may occur. Exercise common sense and caution when using this product and protect against any additional conceivable risks.



## 6.1 Product Overview

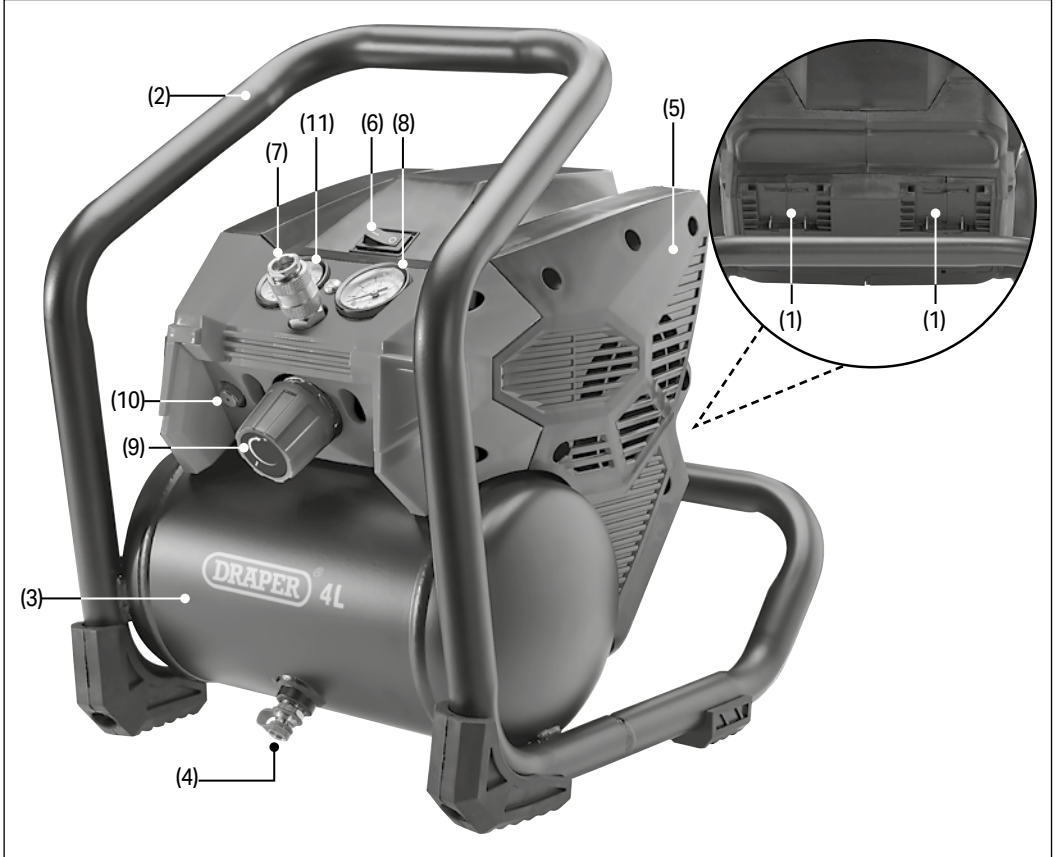

- |                     |                               |
|---------------------|-------------------------------|
| (1) Battery mounts  | (7) Outlet                    |
| (2) Carry handle    | (8) Output pressure gauge     |
| (3) Compressor tank | (9) Output pressure regulator |
| (4) Drain valve     | (10) Safety valve             |
| (5) Motor housing   | (11) Tank pressure gauge      |
| (6) ON/OFF switch   |                               |

## 6.2 Packaging

Keep the product packaging for the duration of the warranty period for reference should the product need to be returned for repair.



**WARNING! Keep packaging materials out of reach of children. Dispose of packaging correctly and responsibly and in accordance with local regulations.**

Please visit [drapertools.com](http://drapertools.com) for our full range of accessories and consumables.

# 7. Operating Instructions

## 7.1 Inserting and Removing the Battery Pack

**Important: ONLY** use this tool with batteries and chargers from the Draper Tools D20 range. The batteries **MUST** be rated 4.0AH or higher. Use of third-party batteries or chargers will invalidate your warranty. Read all the safety and operation instructions provided with these parts before use.

**Important: ALWAYS** ensure that the compressor is switched off when inserting or removing the battery.

This product can be used with either one or two 4.0Ah or 5.0Ah D20 batteries installed and will drain the charge from each battery in turn.

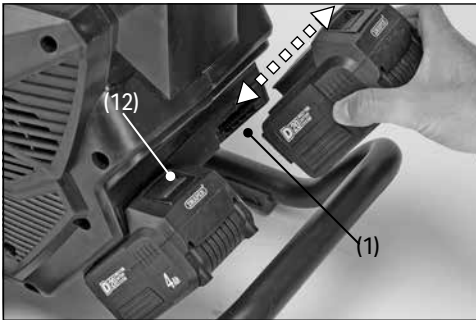

Fig. 1

To install a battery pack, slide it down into the battery mounts at the back of the compressor until it clicks into place.

**Important: DO NOT** force the battery and ensure it is firmly secured before use.

To remove a battery pack, press and hold the battery release button (12) and slide the battery up and out from the compressor.

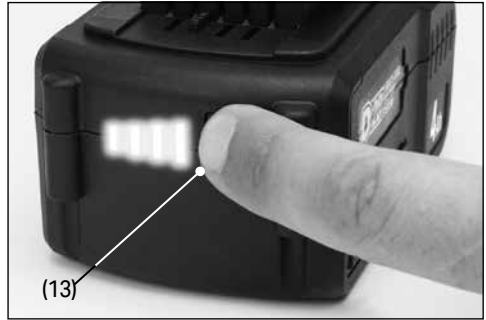

Fig. 2

To view the battery charge on the battery itself, press the charge indicator button (13) at any time.

## 7.2 Connecting an Air Line or Tool

**CAUTION!** ALWAYS check the air line requirements for any tools or air lines connected to this device. DO NOT use this compressor with any air line or tool with which it is not compatible.

**WARNING!** ALWAYS ensure that the air line is interrupted when connecting an air line or tool. DO NOT attempt to connect an air line or tool if air is escaping from the compressor.

**Important:** ALWAYS ensure that the on/off switch (6) is in the off (O) position before attaching or detaching an air line or tool. Draper Tools recommends pressurising the tank first, leaving the output pressure regulator (9) in its lowest position, then connecting the air line and tool.

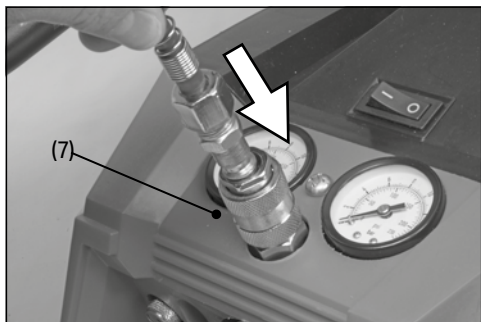

Fig. 3

This device is fitted with a female Euro-style air line adaptor. To connect an air line or tool, insert a male Euro-style air line coupling (attached to the item) into the outlet (7) and allow the collar to snap up to secure it. Once the air line is connected, the output pressure may be set; see **7.4 Setting the Output Pressure**.

**Important:** Draper Tools **strongly** recommends that this compressor is used with an in-line water separator in the air line to protect your connected tools and any sprayed materials. ALWAYS adhere to the manufacturer instructions of any accessories.

**Important:** Draper Tools recommends that PTFE tape is wrapped around all threaded connections along the air line for better airtight seals. For best results, wrap the tape in the opposite direction to the thread.

**Important:** Draper Tools recommends using a suitable whip hose between the connected tool and the air line to reduce vibrations at the tool. Take care as whipping hoses may cause injury.

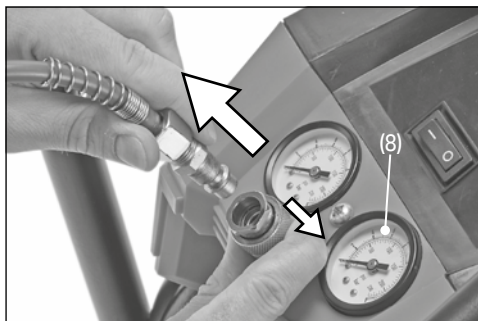

Fig. 4

To detach the connection from the compressor outlet, rotate the output pressure regulator (9) fully anticlockwise and allow the output pressure gauge (8) to drop to zero. Then pull down the collar to eject the connected item.

**Important:** ALWAYS first allow the outlet pressure to drop to zero and grip the air line when detaching it from the compressor to avoid injury from whipping hoses.

**Important:** This product is **NOT** rated for continuous use. The pressurising function of this compressor may be used for a maximum of **90 seconds** in any ten-minute period. ALWAYS allow the device to rest and cool before reuse.

# 7. Operating Instructions

## 7.3 Pressurising the Compressor Tank

**Important:** Place the compressor on a firm and flat surface before use. **DO NOT** move the compressor while it is switched on.

The compressor tank (3) must be pressurised before use. The tank pressure is indicated by the tank pressure gauge (11) (the left of the two gauges).

**Important:** Draper Tools recommends pressurising the tank **BEFORE** attaching an air line or tool.

To pressurise the tank:

1. Turn the output pressure regulator (9) fully anticlockwise and allow the output pressure gauge to drop to zero.
2. Press the on/off switch (6) into the on (I) position and observe the tank pressure gauge.
  - If only a small quantity of air is required, press the on/off switch into the off (O) position when the required pressure is reached.
  - If a full tank is required, allow the compressor to operate until it cuts out automatically.
3. Attach the air line and accessories; see **7.2 Connecting an Air Line or Tool**.
4. Set the desired output pressure; see **7.4 Setting the Output Pressure**.

The tank can be pressurised to a maximum pressure of 8bar, at which point the compressor will automatically cut out. If the compressor remains switched on during use, it will automatically repressurise once its internal pressure drops to approximately 5.4bar.

To reduce the pressure in the tank slightly without connecting a tool, pull gently on the safety valve (10) pin to allow air to escape until the desired pressure is reached.

**Important: DO NOT** use the drain valve to reduce the tank pressure.

For more accurate results when reducing the tank pressure, allow the pressure to drop slightly below the desired level, then repressurise to the level required.

**! WARNING! DO NOT** leave the tank unattended while it is pressurised. **Depressurise the tank if it will not be used for extended periods.**

**! WARNING! The compressor must only be operated for 90 seconds within a 10 minute period. After pressurising the tank, allow 10 minutes for the product to rest before using the air line.**

## 7.4 Setting the Output Pressure

**Important:** This air tool delivers a maximum output pressure of 8bar (116psi). **NEVER** exceed the maximum operating pressure of any component of the connected air line.

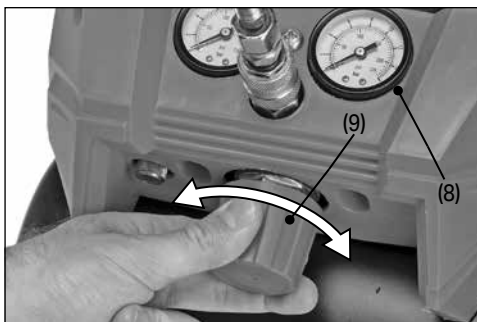

Fig. 5

The output pressure can be set using the output pressure regulator (9) and monitored using the output pressure gauge (8) (the right of the two gauges). The current output pressure can only be viewed when the tank is pressurised.

**Important: ALWAYS** use the minimum outlet pressure required for the operation. Use of excessive pressure will require the compressor to operate and rest more frequently and may cause the operation to take longer.

- To increase the output pressure, rotate the output pressure regulator clockwise.
- To decrease the output pressure, rotate the output pressure regulator anticlockwise.

**Important:** If the regulator is rotated to its full extent in either direction, it may require a few turns before the output pressure begins to change.

When the tank pressure reaches the same level as the output pressure, both will decrease at the same rate unless the tank is repressurised.

## 7.5 Depressurising the Compressor Tank

**Important:** ALWAYS ensure that the compressor is switched off, has completely cooled and the battery has been removed before depressurising the compressor tank.

The compressor tank must be depressurised when not in use and before storage.

To depressurise the tank, use the attached tool to exhaust the pressure. To reduce small amounts of pressure, rotate the output pressure regulator (9) fully anticlockwise and pull gently on the safety valve (10) pin.

## 7.6 The Safety Valve

**Important:** The safety valve (10) has been set at the factory to the value rated for this product. NEVER adjust the safety valve.

The safety valve automatically relieves pressure within the compressor tank if it exceeds the maximum rated pressure for this device.

To test the safety valve, pull gently on the ring pin to allow air to escape from the compressor. If air does not escape, the safety valve is faulty.

If the safety valve is activated during use, switch off the compressor and allow the pressure to return to an acceptable level. Check the compressor for blockages or damage before resuming.

If the safety valve is activated frequently, contact Draper Tools for support.

**Important:** The safety valve MUST be replaced every 12 months, regardless of use, by an authorised service agent; contact Draper Tools for support.

## 7.7 Thermal Overload Protection

This compressor is fitted with a thermal overload safety feature that will cause the motor to shut off if it becomes overheated.

If this safety feature is activated, switch off the compressor and allow it to cool for at least 30 minutes before resuming the operation.

Thermal overload may be caused by:

- Blocked or covered motor air vents
- Excessive pressure inside the tank
- Prolonged use over extended periods
- Use in abnormal ambient temperatures

If the thermal overload protection is triggered frequently, stop the operation and contact Draper Tools for support.

## 7.8 Moisture in Compressed Air

Moisture in compressed air will form into droplets as it leaves the compressor pump. In high-humidity environments or when the compressor is used continuously for an extended period, this moisture may collect in the tank. This moisture is then carried into the connected tool and contaminates the sprayed material, which may damage the finish and the tool itself.

**Important:** ALWAYS drain the compressor tank and air lines of moisture before and after EVERY use and before storing the product.

## 8. Maintenance and Troubleshooting

**Important:** Maintenance and repairs should be carried out **ONLY** by authorised and suitably qualified personnel. **DO NOT** attempt to disassemble the product.

**!** **WARNING! ALWAYS ensure that the on/off switch is in the off (○) position, the battery pack has been removed and the tank has been fully depressurised before performing any maintenance to this product.**

### 8.1 General Maintenance

**Important:** Only the battery pack and charger (not supplied) and any accessories may be replaced by the user.

- Drain the compressor tank before and after **EVERY** use; see 8.2 Draining the Compressor Tank.
- Clean the product using a dry cloth **ONLY**.
  - **NEVER** use solvents or other aggressive substances to clean this product as they may damage plastic or insulated parts
  - **DO NOT** allow liquids to come into contact with the battery pack or battery contacts.
- Check for signs of corrosion or holes around the compressor tank before and after every use.
  - If there is significant evidence of corrosion, have your product inspected by an authorised service engineer; contact Draper Tools for support.

**!** **WARNING! DO NOT use the compressor if you suspect that the structural integrity of the tank has been compromised.**

- Keep the motor vents and air outlet clear and free from dust and debris.
  - Use a vacuum or compressed gas to clean around the vents and outlet.
- Keep the gauges and safety valve clean and free from debris.

**Important:** Take care to ensure that the safety valve is not adjusted during cleaning.

- Have the safety valve replaced every **12 months**, regardless of use, by an authorised service agent; contact Draper Tools for support.

### 8.2 Draining Moisture from the Compressor Tank

**Important:** **ALWAYS** ensure that the compressor is switched off, fully depressurised, completely cooled and that the battery has been removed before draining the compressor tank.

**!** **WARNING! DO NOT open the drain vent while the tank is pressurised.**

Drain the compressor tank of moisture before and after **EVERY** use, and before storing the product.

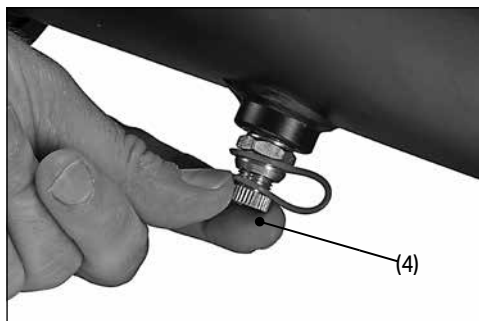

Fig. 6

1. Depressurise the compressor tank; see **7.5 Depressurising the Compressor Tank**.
2. Slowly loosen the drain valve (4) fully until the cap can be detached.
3. Carefully tilt the compressor downwards to drain any excess moisture from inside the tank into a suitable container.
4. Return the compressor to its upright position and tighten the drain valve.

**Important:** Dispose of condensate in accordance with local regulations.

## 8.3 Storing the Compressor

- **ALWAYS**, before storing the product:
  - Remove the battery.
  - Turn the output pressure regulator (9) fully anticlockwise.
  - Depressurise and drain the compressor tank; see **8.2 Draining Moisture from the Compressor Tank**.
  - Detach the air line or tool and hang the open end vertically downward to drain any residual moisture.
  - Open the drain valve (4).
  - Depressurise any other air tools before storing them.
- Store the product in a cool, clean and dry environment, out of direct sunlight and out of the reach of children.
- **DO NOT** store this product in environments exceeding 40°C.
- **ALWAYS** store the product in its upright position.

## 8.4 Troubleshooting

Problem	Possible Cause	Remedy
The compressor does not start up.	The battery is missing or discharged.	Check that at least one battery with sufficient charge is installed.
	The compressor is switched off.	Move the on/off switch to the on position.
	The tank is at maximum pressure.	The tank will automatically depressurise when pressure drops to approx. 5.4bar.
	The ambient temperature is too low.	Move the compressor to an environment with an ambient temperature of 5°C or greater.
	The thermal overload safety feature has been activated.	Switch off the compressor and allow it to cool for at 30 minutes before reuse.
The tank or output pressures are abnormally low.	Connections are loose or a seal is damaged.	Inspect all connections for loose fittings or damaged parts. Have any damaged parts replaced immediately.
	The output pressure regulator is set too low.	Turn the output pressure regulator clockwise to increase the output pressure.
	The safety valve is faulty.	Cease operations immediately and contact Draper Tools for support. <b>DO NOT</b> adjust the safety valve.

## 8. Maintenance and Troubleshooting

---

<b>Problem</b>	<b>Possible Cause</b>	<b>Remedy</b>
Connected air lines and tools are delivering low pressure.	The connected hoses or tools are faulty or are not airtight.	Check connected hoses and tools for signs of cracks, splits or other damage that may cause air leakage.
	Connections are loose or a seal is damaged.	Inspect all connections for loose fittings or damaged parts. Have any damaged parts replaced immediately.
The tank pressure drops when the compressor is switched off.	The output adaptor or drain valve are loose or clogged.	Check and clean the output adaptor and drain valve as necessary.
	The regulator or gauges are faulty.	Contact Draper Tools for support.
Air or liquid output from connected tools contains moisture.	Condensation is present in the compressor tank.	Drain the compressor tank and connected tools and hoses; see <b>8.2</b> .
	The environment is too humid.	Move the compressor to a less humid environment.
The compressor starts and stops excessively.	There is excessive moisture inside the tank.	Drain the compressor tank; see <b>8.2</b> .
The thermal overload safety feature is triggered repeatedly.	The battery voltage is too low.	Recharge the battery before use.
	The motor vents are clogged.	Clean the vents using a vacuum or compressed air.
	The environment is poorly ventilated or the ambient temperature is too high.	Move the compressor to an area with increased ventilation and a lower temperature and allow it to cool.
	A valve is malfunctioning.	Contact Draper Tools for support.
The compressor makes an unusual noise or vibrates excessively.	Fixings are loose or the internal mechanism is damaged.	Check that all external bolts are suitably tight. Contact Draper Tools for support.



## 9. Spares, Returns and Disposal

For spare parts, servicing, and repair and replacement options, please contact the Draper Tools Product Helpline for details of your nearest authorised agent.

Draper Tools will endeavour to hold any spare parts, if applicable, for seven years from the date that it sells the final matching stock item.

Any servicing or repairs carried out by unauthorised personnel or installation of spare parts not supplied by Draper Tools will invalidate your warranty.

At the end of its working life, dispose of the product responsibly and in line with local regulations. Recycle where possible.

- **DO NOT** dispose of this product with domestic waste; most local authorities provide appropriate recycling facilities.
- **DO NOT** incinerate this product or throw it into fire.
- **DO NOT** burn or mutilate batteries; this may release toxic or corrosive substances.
- Dispose of batteries separately and in accordance with local regulations.
- Dispose of condensate in accordance with local regulations.

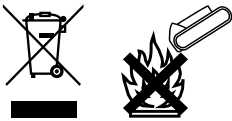

# 10. Explanation of Symbols

---



Read the instruction manual



Wear face mask and safety glasses



Wear ear defenders



Keep out of the reach of children



**Warning!**



Max. tank pressure



Max. output pressure



Compressor tank capacity



**DO NOT** incinerate or throw onto fire



WEEE -

Waste Electrical & Electronic Equipment

Do not dispose of Waste Electrical & Electronic Equipment in with domestic rubbish



European conformity



UK Conformity Assessed



## Contact Details

### **Draper Tools**

Draper Tools Limited  
Hursley Road  
Chandler's Ford  
Eastleigh  
Hampshire  
SO53 1YF  
UK

**Website:** [drapertools.com](http://drapertools.com)

**Email:** [sales@drapertools.com](mailto:sales@drapertools.com)

**Product Helpline:** +44 (0) 23 8049 4344

**Telephone Sales Desk:** +44 (0) 23 8049 4333

**General Enquiries:** +44 (0) 23 8026 6355

**General Fax:** +44 (0) 23 8026 0784

### **Delta International**

Delta International BV  
Oude Graaf 8  
6002 NL  
Weert  
Netherlands

Please contact the Draper Tools Product Helpline for repair and servicing enquiries.